



MOROOKA

MST-1500VDL / MST-1500VDLG



- Maximum payload is 7t
- HARDOX is adopted for the dump

The HARDOX dump

HARDOX with high-strength and long-term use at forestry sites is adopted for the dump. HARDOX's long service life reduces running costs.



Improved work safety

LED lights above the cabin, large mirrors for better driving vision, and an easy-to-maintain front bumper enhance driving safety.



Driver's seat with excellent comfortability

The synthetic leather operator seat that is water-repellent and stain-resistant and a more compact console box provides a spacious and comfortable driving experience.



Reliable forestry-specific design

Designed specifically for the forestry industry, this machine can maintain the optimum weight balance when loading logs and improve stability when transporting lumber.



Strong undercarriage

Morooka's strong undercarriage provides excellent tramping performance and enhances mobility in forestry work sites with poor footing. Additionally, the wide, thick rubber crawlers are also durable and reduce running costs.



Main specifications

MODEL	MST-1500VDL	MST-1500VDLG
PERFORMANCE		
Maximum Payload	7,000	6,000
Loading Capacity Struck/Heaped	9.6/6.7	
Speed ¹ High / Low	25.5/41.8	28.3/42.3
MACHINE DIMENSION & WEIGHT		
Machine Weight	10,900	12,100
Overall Length	6,680	6,950
Overall Width for transport	2,750	
Overall Height	2,940	3,280
Min. Ground Clearance	510	
Crawler Width	700	
Crawler Outer Width	2,500	2,500
DUMP BED (INNER)		
Shape	Flat bed	
Length x Width	3,900 x 2,300	3,700 x 2,300
ENGINE		
Name	Cummins B6.7	
Nominal Output/rpm	168/2,200	
Grapple		
Name	—	Cranab FC45DT
Grapple capacity	—	300kg x 8.0m
FUEL		
	Diesel	
TANK CAPACITY		
Fuel Tank Capacity	200	
Hydraulic Oil Tank Capacity	100	
DEF Tank Capacity	19	
Name and Type of Vehicle	MST-1500VDL-VB	MST-1500VDLG-VB
Name and Model of Engine	Cummins QSB6.7-4C	
Emission Standard	Tier4 Final/ EU Stage IV	

Body dimensions

[Standard]

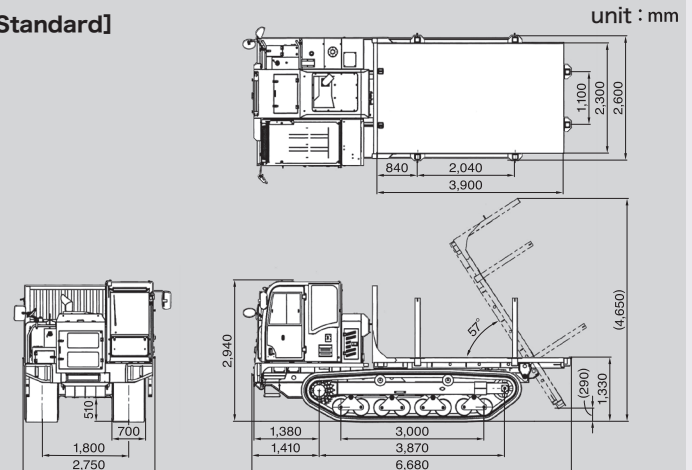

[Grapple]

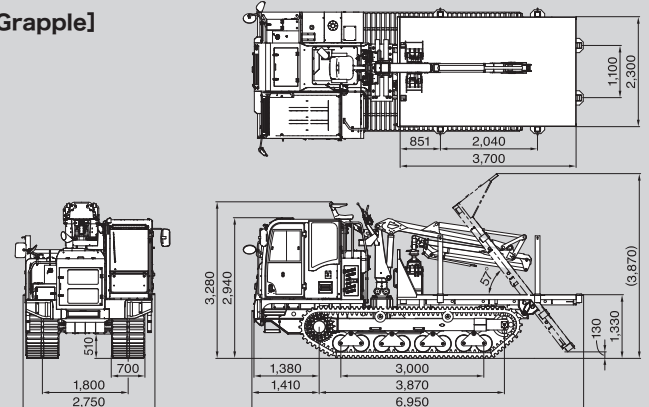

MOROOKA
Morooka Co., Ltd.



URL : www.morooka.com (English) www.morooka.co.jp (Japanese)
Postal Code : 301-0031
358 Shoubeeshindenmachi, Ryugasaki city, Ibaraki Prefecture, Japan
TEL : +81-297-66-2111 TEL : (Overseas Sales Dept.) : +81-297-86-9034

CONTACT